

남일벨트시스템

하바지트(Habasit) 제품 카탈로그

Habasit 제작 공구 및 액세서리

제품 개요

벨트 접합·수리를 위한 Habasit 공식 제작 공구 일람입니다. 핫프레스·초음파 용착기·벨트 커터 등 전문 장비를 소개합니다.

주요 특징

- 벨트 접합용 핫프레스
- 초음파 용착기
- 벨트 커터·스카이빙 공구
- CIP 세척 유닛·벨트 스크레이퍼
- 벨트 장력 측정기

남일벨트시스템 (Namil Belt System) | 하바지트(Habasit) 공식 파트너

대표: 홍중수 | 사업자등록번호: 268-06-02265 | 서울시 동대문구 한천로2길 16, 212호(덕암빌딩)

전화: 02-6084-7795 | 이메일: namilsystem@naver.com | 홈페이지: namilbeltsystem.github.io

Habasit Fabrication

Tools and Hot Presses

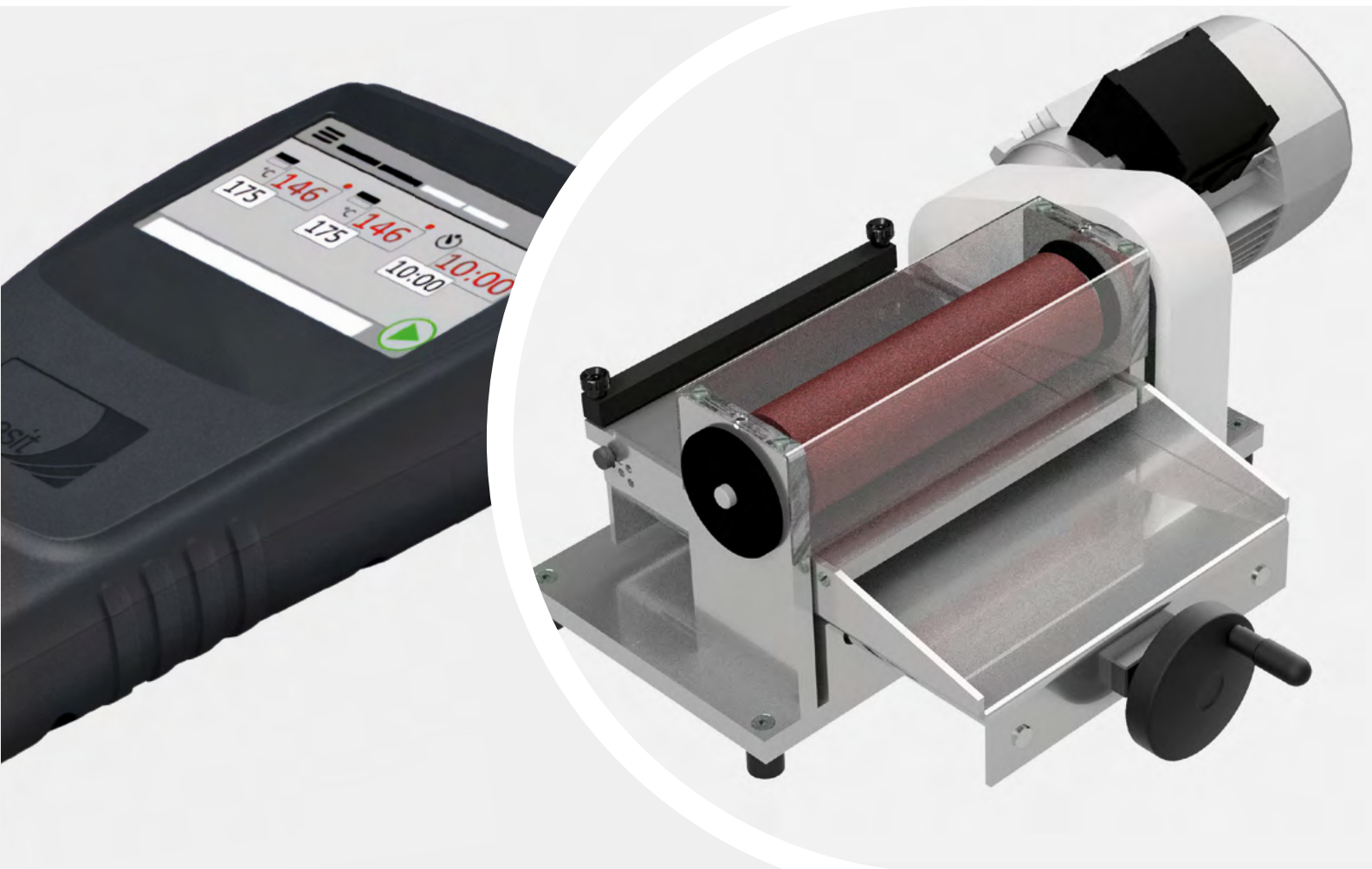

Contents

Introduction	3
Joining methods	3
Cutting devices	4
Skiving devices	5
Die-cutting devices	6
Quickmelt joining devices	9
Flexproof joining devices	11
Cooling devices	12
Guide rails	13
Thermofix joining devices	15
Lightweight presses	17
Presses for Habasit® Cleandrive belts	18
Cutting accessories for Habasit® Cleandrive belts	19
Ad-on for PQ-03 Habasit® Cleandrive presses	20
Press range	21
Control units	23
Cooling units and accessories	24
Presses kits - Details	25
Presses for timing belts	29
Joining plates for timing belts	30
Our services	32
Contacts us	34

Introduction

Effective and efficient fabrication of belts on site is made possible with the broad range of Habasit tools.

The available equipment series cover the requirements of standard or specialized in-house fabrication, as well as on-site installations of belts and tapes.

- The range includes:
- Cutters and slitters for length and width
- Die-cutter and skiving devices for belt end preparation
- Hot-pressing devices for the joining process
- Welders and welding machines for belts, profiles, etc.
- Accessories such as coiling devices, regulating units, guide rails, etc.

Joining methods

Habasit developed three different joining techniques that maximize the belt performances and lifetime, matching the application needs.

Habasit belts are joined using three different standard techniques, each providing different features and advantages, based on the application and the product type to be joined.

Thermofix

This is the method to join non-thermoplastic belts and it consists in three steps: belt skiving, adhesive application and hot-pressing.

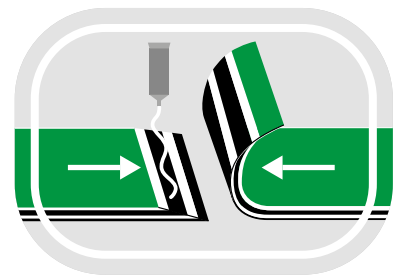

Flexproof

This method is the most commonly used on conveyor and power-transmission belts based on thermoplastic materials. It requires the zig-zag preparation of the belt ends and the hot-pressing. It ensures long service life and excellent performances.

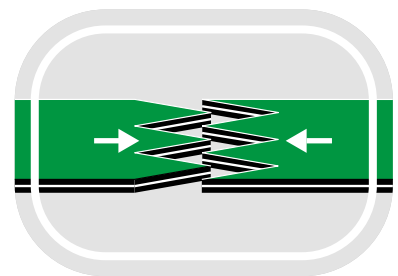

Quickmelt

It is the easiest joining technique, mostly used on machine tapes and monolithic belts. It requires the bias cutting of the belt ends and the hot-pressing to obtain a flexible and reliable joint.

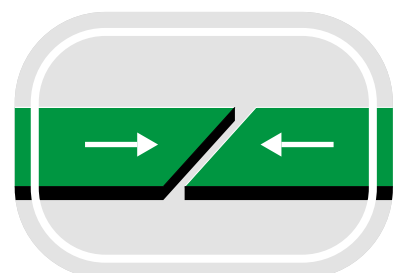

Cutting devices

S-16

Manual scissors for cutting round belts, up to 15 mm in diameter.

Ideal for Polycord, Habicord, and small section extruded profiles.



AQ-40

Manual scissors for cutting flat belts, up to 40 mm wide and 3 mm thick. Marks on the cutting bed allow angled cuts.

Designed for machine tapes, requiring Quickmelt joining.



Details				Power supply					Product type					Method			Dimensions					
Product name	Max. belt width	Ordering code	Article name	Power [W]	Manual	1 x 120 V	1 x 230 V	3 x 230 V	3 x 400 V	Timing belts	Conveyor belts	Habasit Cleandrive™	Round belts	Power transmission	Machine tapes	Flexproof	Quickmelt	Thermofix	Length [mm]	Width [mm]	Height [mm]	Weight [kg]
S-16	15	H080690010	S-16/0		●								●				●		165	40	45	0.2
AQ-40	40	H080690020	AQ-40/0		●						○	●		●	●		●		220	80	55	0.7

● Recommended ○ Possible

Key to symbols

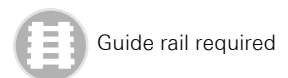
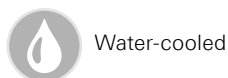
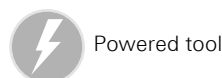

Cross cutting devices

BC-1000-1600

The BC cross cutters are portable belt cutters featuring a bi-directional blade and foldable guides that ensure precise 90° cutting of belts. Shielded blade and absence of pinch provide full operator safety. These tools are lightweight and user-friendly for on-site use, but also suitable for stationary application with dedicated workbenches.

BC-1000 is the version for cutting belts up to 1000 mm.

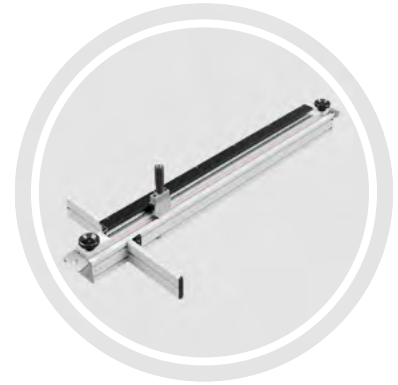
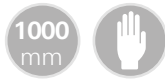

BC-1600 is the version for cutting belts up to 1600 mm.



Details				Power supply					Product type					Method			Dimensions					
Product name	Max. belt width	Ordering code	Article name	Power [W]	Manual	1 x 120 V	1 x 230 V	3 x 230 V	3 x 400 V	Timing belts	Conveyor belts	Habasit Cleandrive™	Round belts	Power transmission	Machine tapes	Flexproof	Quickmelt	Thermofix	Length [mm]	Width [mm]	Height [mm]	Weight [kg]
BC-1000	1000	H088000757	BC-1000/0		•						•					•	•		1420	600	300	17
BC-1600	1600	H088000758	BC-1600/0		•						•					•	•		2020	600	300	22

Skiving devices

AT-60

Manual skiving tool, based on grinding disc, for belts requiring Thermofix joining, up to 60 mm wide and 2 mm thick.

This tool is designed for occasional preparation of power transmission belts and spindle tapes.



AT-201

Skiving tool, based on grinding roller, for belts requiring Thermofix joining, up to 200 mm wide and 7 mm thick. The tool is equipped with a high-torque motor and is suitable for preparing machine tapes and power transmission belts, up to small batches.

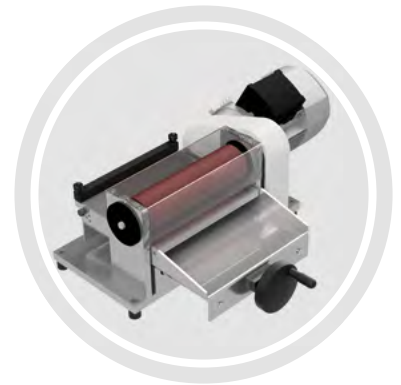

A-600

Skiving tool, based on belt sander, for belts requiring Thermofix joining, up to 600 mm wide and 6 mm thick. Wider belts can also be processed in multiple steps.

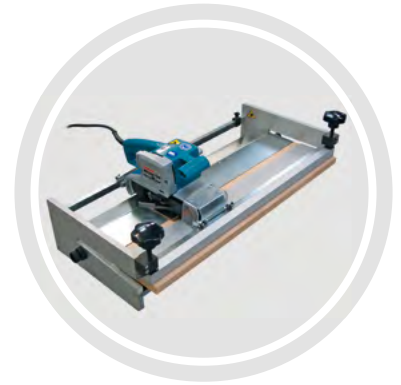
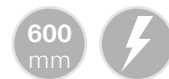

Details				Power supply					Product type				Method			Dimensions						
Product name	Max. belt width	Ordering code	Article name	Power [W]	Manual	1 x 120 V	1 x 230 V	3 x 230 V	3 x 400 V	Timing belts	Conveyor belts	Habasit Cleandrive™	Round belts	Power transmission	Machine tapes	Flexproof	Quickmelt	Thermofix	Length [mm]	Width [mm]	Height [mm]	Weight [kg]
AT-60	60	H080690050	AT-60/0		●									●	●			●	220	190	85	1.5
AT-201	200	H088000731	AT-201/8	750			●				●			●	●			●	600	390	185	18
AT-201	200	H088000732	AT-201/6	750		●					●			●	●			●	600	390	185	18
A-600	600	H080690360	A-600/8	750			●				●			●	○			●	875	445	255	32
A-600	600	H080690350	A-600/6	750		●					●			●	○			●	875	445	255	32

● Recommended ○ Possible

Die-cutting devices

A-4201

Simple and effective kit for die-cutting of Flexproof geometries on thermoplastic belts up to 6 mm thick. The adhesive tape with zig-zaf pattern enables proper belt ends preparation by means of the chisel. The A-4201 is particularly suitable for on-site installations or occasional use.



AF-42

Manual tool for die-cutting of 10x120 Flexproof geometry on thermoplastic belts up to 40 mm wide. Specifically designed for the preparation of tangential power transmission belts.

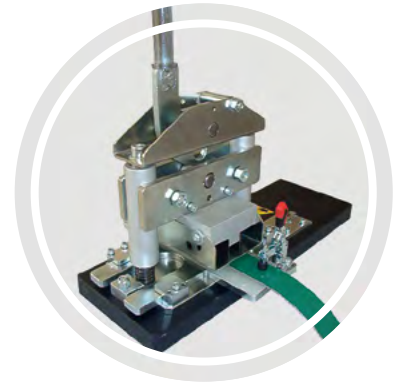

AF-102

Manual scissor tool for preparation of 8x30 Flexproof geometry on thermoplastic belts up to 100 mm wide and 2 mm thick. Ideal for machine tapes and spindle tapes.



Details				Power supply					Product type					Method			Dimensions						
Product name	Max. belt width	Ordering code	Article name	Power [W]	Manual	1 x 120 V	1 x 230 V	3 x 230 V	3 x 400 V	Timing belts	Conveyor belts	Habasit Cleandrive™	Round belts	Power transmission	Machine tapes	Flexproof	Quickmelt	Thermofix	Length [mm]	Width [mm]	Height [mm]	Weight [kg]	
A-4201	ANY	H088000629	A-4201/0		●						●			●		●							2.8
AF-42	40	H088000149	AF-42/0		●						○			●		●			445	230	260		8
AF-102	100	H080690060	AF-102/0		●										●	●			200	52	85		1.6

● Recommended ○ Possible

Die-cutting devices

AFH-61

The AFH-61 is an handheld Flexproof die-cutting device suitable for spindle tapes and machine tapes up to 60 mm wide. The cutting head is fixed with one of the following two cutting geometries:

- 5.5x35 mm (already available)
- 5.5x46 mm (available from Q3/2025)



AFH-201TB

The AFH-201TB is an handheld Flexproof die-cutting device suitable for fabric belts or timing belts, even with steel cords, up to 200 mm wide. The tool is equipped with a 10x80 die-cutting head while additional geometries are available on request. This device will be available from Q3/2025.

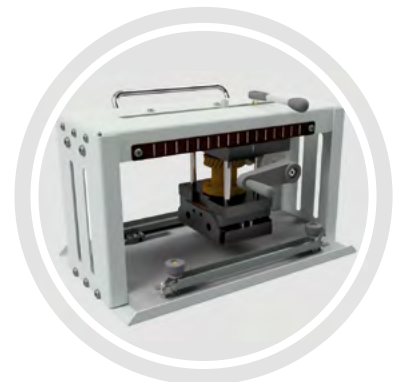

Details				Power supply				Product type				Method			Dimensions							
Product name	Max. belt width	Ordering code	Article name	Power [W]	Manual	1 x 120 V	1 x 230 V	3 x 230 V	3 x 400 V	Timing belts	Conveyor belts	Habasit Cleandrive™	Round belts	Power transmission	Machine tapes	Flexproof	Quickmelt	Thermofix	Length [mm]	Width [mm]	Height [mm]	Weight [kg]
AFH-61	60	H088000771	AFH-61/0 5,5/35		●										●	●			230	200	280	5.5
AFH-61	60	H088000748	AFH-61/0 5,5/46		●										●	●			230	200	280	5.5
AFH-201TB	200	H088000744	AFH-201TB/0		●					●	●			●	●	●			400	252	300	20

● Recommended ○ Possible

Die-cutting devices

AFL-601/0

Designed for Flexproof and Step-Flexproof preparation of belts up to 10 mm thick and 600 mm wide, the AFL-601 is the ideal solution for on-site use or small batches fabrication. Although it is manually actuated, the indexing and punching operation are provided with the same action, making its use extremely easy, quick and easy.

The tool is equipped with a 20x80 die-cutting head while additional geometries are available on request. Wider belts can also be processed in multiple steps.

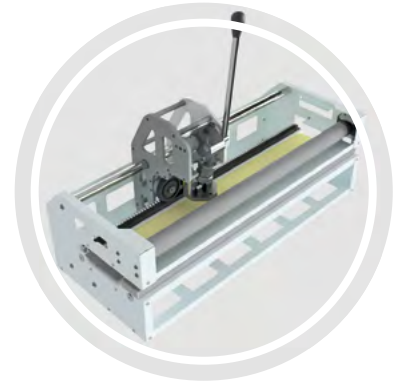

Details				Power supply					Product type					Method		Dimensions						
Product name	Max. belt width	Ordering code	Article name	Power [W]	Manual	1 x 120 V	1 x 230 V	3 x 230 V	3 x 400 V	Timing belts	Conveyor belts	Habasit Cleandrive™	Round belts	Power transmission	Machine tapes	Flexproof	Quickmelt	Thermofix	Length [mm]	Width [mm]	Height [mm]	Weight [kg]
AFL-601	600	H088000671	AFL-601/0		●						●			●	●	●			910	450	440	41

● Recommended ○ Possible

Die-cutting heads					
Product name	Geometry [mm]	Item number	Article name	Dimensions [mm]	Weight [kg]
FDCH-AFL	10/50	H08D019449	FDCH-AFL-10/50	140L x 80W x 45H	1.5
FDCH-AFL	10/80	H08D019413	FDCH-AFL-10/80	140L x 80W x 45H	1.7
FDCH-AFL	10/120	H08D018683	FDCH-AFL-10/120	140L x 80W x 45H	1.7
FDCH-AFL	20/50	H08D019414	FDCH-AFL-20/50	140L x 80W x 45H	1.7
FDCH-AFL	20/80	H08D018694	FDCH-AFL-20/80	140L x 80W x 45H	1.7

Quickmelt joining devices

PQ-01

Quickmelt welding tool, designed for joining round belts. It consists of a W-01 welder and CO-01 table stand for belt ends positioning.



PQ-02

Quickmelt welding tool, designed for joining round belts. It consists of a W-01 welder and CO-02 clamping device.



Details				Power supply					Product type					Method			Dimensions					
Product name	Max. belt width	Ordering code	Article name	Power [W]	Manual	1 x 120 V	1 x 230 V	3 x 230 V	3 x 400 V	Timing belts	Conveyor belts	Habasit Cleandrive™	Round belts	Power transmission	Machine tapes	Flexproof	Quickmelt	Thermofix	Length [mm]	Width [mm]	Height [mm]	Weight [kg]
PQ-01	15	H088000526	PQ-01/8	80			●						●				●		420	140	120	0.5
PQ-01	15	H088000525	PQ-01/6	80		●							●				●		420	140	120	0.5
PQ-02	15	H088000541	PQ-02/8	80			●						●				●		420	140	120	0.3
PQ-02	15	H088000540	PQ-02/6	80		●							●				●		420	140	120	0.3

● Recommended ○ Possible

Quickmelt joining devices

W-01

The W-01 is a welder designed for Quickmelt joining of thermoplastic round belts up to a diameter of 15 mm.



PQ-60

Hot-pressing device for joining of thermoplastic belts up to 50 mm wide and 3.6 mm thick. For maximum flexibility, the working temperature and the cycle time can be set via a keypad and showed by a digital display. Especially designed for machine tapes and spindle tapes. Specific guide rails are required and CD-60 cooling device is recommended for proper joining.



Details				Power supply					Product type					Method			Dimensions					
Product name	Max. belt width	Ordering code	Article name	Power [W]	Manual	1 x 120 V	1 x 230 V	3 x 230 V	3 x 400 V	Timing belts	Conveyor belts	Habasit Cleandrive™	Round belts	Power transmission	Machine tapes	Flexproof	Quickmelt	Thermofix	Length [mm]	Width [mm]	Height [mm]	Weight [kg]
W-01	15	H088000562	W-01/8	80			●						●				●		250	50	50	0.2
W-01	15	H088000561	W-01/6	80		●							●				●		250	50	50	0.2
PQ-60	50	H088000768	PQ-60/8	450			●			○					●	○	●	●	280	70	120	1
PQ-60	50	H088000769	PQ-60/6	450		●				○					●	○	●	●	280	70	120	1

● Recommended ○ Possible

Flexproof joining devices

PF-62

Hot-pressing device for Flexproof joining of thermoplastic belts up to 60 mm wide and 5 mm thick. Designed for tangential power transmission belts. Specific guide rails are required and CD-61 cooling device is recommended for proper joining.



PF-100S

Hot-pressing device for Flexproof joining of thermoplastic belts up to 100 mm wide and 2.5 mm thick. Specific guide rails are required for proper joining.



PF-101

Hot-pressing device for Flexproof and Thermofix joining of thermoplastic belts up to 100 mm wide and 6 mm thick. The external control unit provides full management of the joining cycle parameters (temperature and time) and the cooling fan system. It is delivered in a kit including a PMR-102 control unit.



Details				Power supply					Product type					Method			Dimensions					
Product name	Max. belt width	Ordering code	Article name	Power [W]	Manual	1 x 120 V	1 x 230 V	3 x 230 V	3 x 400 V	Timing belts	Conveyor belts	Habasit Cleandrive™	Round belts	Power transmission	Machine tapes	Flexproof	Quickmelt	Thermofix	Length [mm]	Width [mm]	Height [mm]	Weight [kg]
PF-62	60	H088000410	PF-62/8	500			●				●			●	○	●			320	176	116	2
PF-62	60	H088000409	PF-62/6	500		●					●			●	○	●			320	176	116	2
PF-100S	100	H080690230	PF-100S/8	150			●				●			○	○	●			285	102	102	2
PF-100S	100	H080690210	PF-100S/6	150		●					●			○	○	●			285	102	102	2
PF-101	100	H080690410	PF-101/8	700			●				●			●	○	●		●	260	190	145	4
PF-101	100	H080690400	PF-101/6	700		●					●			●	○	●		●	260	190	145	4

● Recommended ○ Possible

Cooling devices

CD-60

The CD-60 is a cooling device to be used in combination with PQ-59 hot-pressing device to perform the Quickmelt and Flexproof (50 mm finger) joining system. The belt is joined in a guide rail fixed with two spring clips and welded with the PQ- 59. After welding, it is transferred to the CD-60 cooling tong to cool the belt down under a predetermined pressure.



CD-61

The CD-61 is a cooling device to be used in combination with PF-62 hot-pressing device to perform the Flexproof (120 mm finger) joining system. The belt is joined in a guide rail fixed with two spring clips and welded with the PF-62. After welding, it is transferred to the CD-61 cooling tong to cool the belt down under a predetermined pressure.



Details				Power supply					Product type					Method			Dimensions					
Product name	Max. belt width	Ordering code	Article name	Power [W]	Manual	1 x 120 V	1 x 230 V	3 x 230 V	3 x 400 V	Timing belts	Conveyor belts	Habasit Cleandrive™	Round belts	Power transmission	Machine tapes	Flexproof	Quickmelt	Thermofix	Length [mm]	Width [mm]	Height [mm]	Weight [kg]
CD-60	50	H080690030	CD-60/0		●									●	●	●	●		270	60	100	0.5
CD-61	60	H080690040	CD-61/0		●									●		●			270	150	90	0.6

- Recommended ○ Possible

Guide rails

When using hot-pressing tools, in order to properly position the belt ends and obtain a perfect joining result, specific guide rails have been designed for our PQ-60, PF-62 and PF-100S devices. A large choice of fixed-width guide rails is available, and if you are looking for high flexibility (or minimal on site setup) adjustable versions are also available.

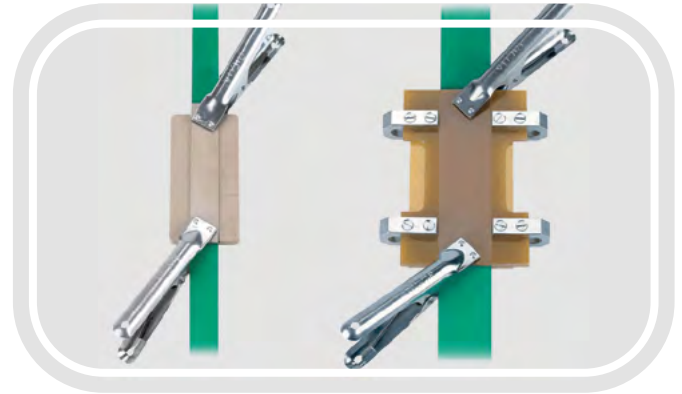

Fixed width

Adjustable width

	Guide rails for PQ-60	Guide rails for PF-100S	Guide rails for PF-62
Width [mm]	Ordering code		
6	H08D023840		
8	H08D023841		
10	H08D023843		
11	H08D023844		
12	H08D023845		
13	H08D023847		
14	H08D023848		
15	H08D023849		
16	H08D023851		
18	H08D023852		H080672214
20	H08D023854		H080672209
22	H08D023855		
25	H08D023857		
30	H08D023860		H080672215
35	H08D023863		
40	H08D023865		H080672212
42		H080672226	
50	H08D023869		
55		H080672225	
60		H080672224	H080672213
74		H080672223	
80		H080672222	
90		H080672221	
100		H080672220	
Metric kit	H080672201 (*)		H080672210 (**)

* Adjustable guide rails kit with included the plates to work with the following belt widths (mm): 25, 30, 35, 40, 45, 50

** Adjustable guide rails kit with included the plates to work with the following belt widths (mm): 25, 30, 35, 38, 40, 42, 45, 50, 60

Guide rails

	Guide rails for PQ-60	Guide rails for PF-100S	Guide rails for PF-62
			
Width [inch]	Ordering code		
3/8"	H08D023842		
1/2"	H08D023846		
5/8"	H08D023850		
3/4"	H08D023853		
7/8"	H08D023856		
1"	H08D023858		
1 1/8"	H08D023859		
1 1/4"	H08D023861		
1 3/8"	H08D023862		
1 1/2"	H08D023864		
1 5/8"	H08D023866		
1 3/4"	H08D023867		
1 7/8"	H08D023868		
2"	H08D023870		
Imperial kit	H080672202 (*)		H080672211 (**)

* Adjustable guide rails kit with included the plates to work with the following belt widths (inch): 3/4", 1", 1 1/4", 1 1/2", 1 3/4", 2"

** Adjustable guide rails kit with included the plates to work with the following belt widths (inch): 1", 1 1/4", 1 3/8", 1 1/2", 1 5/8", 1 3/4", 2", 2 1/4"

Thermofix joining devices

PT-50

Hot-pressing device for Thermofix joining of belts up to 50 mm wide and 2 mm thick. It is especially suitable for offline joining of spindle tapes and machine tapes.



PT-55

Hot-pressing device for Thermofix joining of belts up to 50 mm wide and 2.5 mm thick. Thanks to the portable body, it is especially suitable for joining spindle tapes and machine tapes directly on-site.



PT-100

Hot-pressing device for Thermofix offline joining of belts up to 100 mm wide and 6 mm thick.



PT-103

Hot-pressing device for Thermofix joining of belts up to 100 mm wide and 2.5 mm thick. Thanks to the portable body, it is especially suitable for joining power transmission belts directly on-site.



Thermofix joining devices

PT-103S

Hot-pressing device for Thermofix joining of belts up to 100 mm wide and 2.5 mm thick. Thanks to the portable body, it is especially suitable for joining of power transmission belts directly on-site. The integrated guide rail permits an easy positioning of belt ends.



PTL-300

Hot-pressing device for Thermofix joining of belts up to 300 mm wide and 10 mm thick. The integrated bar clamps permit an easy and steady positioning of the belt ends.

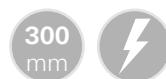

Details				Power supply					Product type					Method			Dimensions					
Product name	Max. belt width	Ordering code	Article name	Power [W]	Manual	1 x 120 V	1 x 230 V	3 x 230 V	3 x 400 V	Timing belts	Conveyor belts	Habasit Cleandrive™	Round belts	Power transmission	Machine tapes	Flexproof	Quickmelt	Thermofix	Length [mm]	Width [mm]	Height [mm]	Weight [kg]
PT-50	50	H080691450	PT-50/8	75			●			○				○	●			●	215	120	84	1
PT-50	50	H080691430	PT-50/6	75		●				○				○	●			●	215	120	84	1
PT-55	50	H080691420	PT-55/8	150			●			○				○	●			●	280	63	95	1
PT-55	50	H080691400	PT-55/6	150		●				○				○	●			●	280	63	95	1
PT-100	100	H080690090	PT-100/8	150			●			○				○	●			●	285	128	102	2
PT-100	100	H080690070	PT-100/6	150		●				○				○	●			●	285	128	102	2
PT-103	100	H080690120	PT-103/8	150			●			○				○	●			●	289	96	56	1
PT-103	100	H080690100	PT-103/6	150		●				○				○	●			●	289	96	56	1
PT-103S	100	H080690150	PT-103S/8	150			●			○				○	●			●	300	250	56	1
PT-103S	100	H080690130	PT-103S/6	150		●				○				○	●			●	300	250	56	1
PTL-300	300	H088000686	PTL-300/8	800			●			●				●	○			●	300	475	150	18
PTL-300	300	H088000685	PTL-300/6	800		●				●				●	○			●	300	475	150	18

● Recommended ○ Possible

Lightweight presses

PML series

Compact and lightweight, PML hot-pressing devices are designed to easily and quickly join fabric belts and, in combination with proper joining plate, even timing belts.

PML presses are delivered with a PMR-103 control unit.



Details			Power supply				Product type				Method			Dimensions				Details				
Max belt width	Ordering code	Article name	Power [W]	1 x 120 V	1 x 230 V	3 x 230 V	3 x 400 V	Conveyor belts	Habasit® Cleandrive	Power transmission	Machine tapes	Timing belts	Flexproof	Quickmelt	Thermofix	Length [mm]	Width [mm]	Height [mm]	Weight [kg]	Kit version	Control unit	Included accessories
PML air-cooled, multipurpose portable																						
100	H088000631	PML-100/8	1000		•			•	•	•	•	•	•	•	•	300	260	150	6.5	Mobile	PMR-103/8	Suitcase
	H088000630	PML-100/6	1000	•				•	•	•	•	•	•	•	•	300	260	150	6.5	Mobile	PMR-103/6	Suitcase
200	H088000633	PML-200/8	1200		•			•	•	•	•	•	•	•	•	300	350	150	9.5	Mobile	PMR-103/8	Suitcase
	H088000632	PML-200/6	1200	•				•	•	•	•	•	•	•	•	300	350	150	9.5	Mobile	PMR-103/6	Suitcase
300	H088000635	PML-300/8	1600		•			•	•	•	•	•	•	•	•	300	475	150	13	Mobile	PMR-103/8	Trolley
	H088000634	PML-300/6	1600	•				•	•	•	•	•	•	•	•	300	475	150	13	Mobile	PMR-103/6	Trolley
600	H088000637	PML-600/8	1600		•			•	•	•	•	•	•	•	•	300	775	150	28	Mobile	PMR-103/8	Flight case
	H088000636	PML-600/6	1600	•				•	•	•	•	•	•	•	•	300	775	150	28	Mobile	PMR-103/6	Flight case

See pages 31 and 32 for Habasit joining plate selection

Presses for Habasit® Cleandrive belts

PQ-03 series

The PQ-03 hot-pressing devices, have been specifically developed for easy joining of Habasit® Cleandrive belts up to 10 mm thick.

They are delivered in a turn-key kit that includes the PMR-103 control units and all the needed accessories and auxiliaries to be immediately operative. Thanks to the air-cooling system, no water is needed.

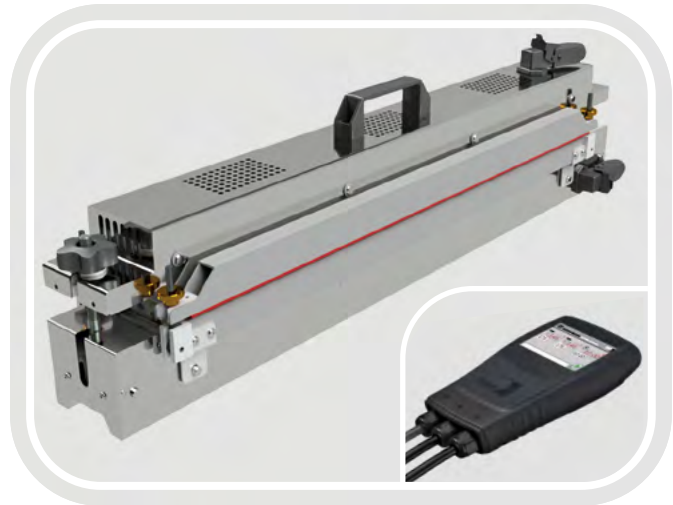

Details			Power supply				Product type				Method			Dimensions				Details							
Max belt width	Ordering code	Article name	Power [W]	1 x 120 V	1 x 230 V	3 x 230 V	3 x 400 V	Conveyor belts	Habasit® Cleandrive	Power transmission	Machine tapes	Timing belts	Flexproof	Quickmelt	Thermofix	Length [mm]	Width [mm]	Height [mm]	Weight [kg]	kit version	Control unit	Included accessories			
																						Air pump MT01	Cutter KDS-HI	Ruler AQ-602	Flightcase
PQ-03 Cleandrive™ presses																									
400	H088000521	PQ-403/8	1000	•				•					•		670	165	230	15	Mobile	PMR-103/8	•	•	•	•	
	H088000520	PQ-403/6	1000	•				•					•		670	165	230	15	Mobile	PMR-103/6	•	•	•	•	
600	H088000412	PQ-603/8	1200		•			•					•		840	150	210	19	Mobile	PMR-103/8	•	•	•	•	
	H088000411	PQ-603/6	1200	•				•					•		840	150	210	19	Mobile	PMR-103/6	•	•	•	•	
900	H088000569	PQ-903/8	1800		•			•					•		1175	164	267	36	Mobile	PMR-103/8	•	•	•	•	
	H088000568	PQ-903/6	1600	•				•					•		1175	164	267	36	Mobile	PMR-103/6	•	•	•	•	
1300	H088000457	PQ-1303/8	2900		•			•					•		1690	165	260	52	Mobile	PMR-103/8	•	•	•	•	
	H088000456	PQ-1303/6	1600	•				•					•		1690	165	260	52	Mobile	PMR-103/6	•	•	•	•	
1800	H088000506	PQ-1803/5	4700				•	•					•		2220	300	300	126	Mobile	PMR-07/5	•	•	•		
	H088000505	PQ-1803/4	3600			•		•					•		2220	300	320	126	Mobile	PMR-07/4	•	•	•		

Cutting accessories for Habasit® Cleandrive belts

AQ-603

Manual cutting device for safe cutting of Habasit® Cleandrive belts up to the required length. Sliding along the drive bars, the AQ-603 allows to perform a cross-cut on Habasit® Cleandrive belts (CD.M25 and CD.M50) in any width.



AQ-604

Ruler for for clean cutting of Habasit® Cleandrive belts with LUGS (CD.M40) up to the required length. Sliding along the drive bars, the AQ-604 allows to perform a cross-cut on Habasit® Cleandrive belts (CD.M40) in any width.

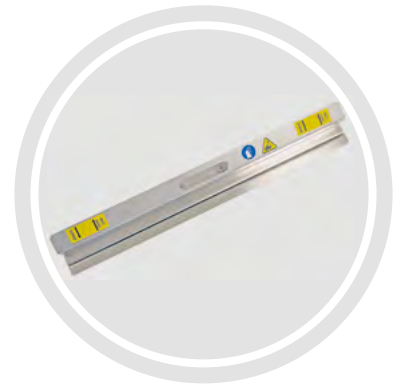

Details				Power supply				Product type			Method			Dimensions					
Product name	Max belt width	Ordering code	Article name	Power [W]	Manual	1 x 120 V	1 x 230 V	3 x 230 V	3 x 400 V	Habasit® Cleandrive CD.M25	Habasit® Cleandrive CD.M40	Habasit® Cleandrive CD.M50	Flexproof	Quickmelt	Thermofix	Length [mm]	Width [mm]	Height [mm]	Weight [kg]
PML air-cooled, multipurpose portable																			
AQ-603	ANY	H08D016357	AQ-603/0		•					•		•		•		650	102	196	3.2
AQ-604	ANY	H08D016888	AQ-604/0		•						•			•		650	95	74	3.1

Ad-on for PQ-03 Habasit® Cleandrive presses

When Habasit® Cleandrive CD.M40.L monolithic reinforced conveyor belts have to be joined by using PQ-03 presses, dedicated add-on plates are required.



Details				Power supply				Product type				Method			Dimensions				
Max belt width	Ordering code	Article name	Suitable for	Power [W]	1 x 120 V	1 x 230 V	3 x 230 V	3 x 400 V	Conveyor belts	Habasit Cleandrive™	Power transmission	Machine tapes	Flexproof	Quickmelt	Thermofix	Length [mm]	Width [mm]	Height [mm]	Weight [kg]
PQ-03 Add-on																			
400	H088000650	PQ-403.CD.M40.L/8	PQ-403/8	500		•				•				•		630	148	44	3
	H088000649	PQ-403.CD.M40.L/6	PQ-403/6	450	•					•				•		630	148	44	3
600	H088000652	PQ-603.CD.M40.L/8	PQ-603/8	600		•				•				•		824	148	44	4
	H088000651	PQ-603.CD.M40.L/6	PQ-603/6	600	•					•				•		824	148	44	4
900	H088000654	PQ-903.CD.M40.L/8	PQ-903/8	900		•				•				•		1145	148	44	6
	H088000653	PQ-903.CD.M40.L/6	PQ-903/6	800	•					•				•		1145	148	44	6
1300	H088000656	PQ-1303.CD.M40.L/8	PQ-1303/8	1400		•				•				•		1645	148	44	8
	H088000655	PQ-1303.CD.M40.L/6	PQ-1303/6	800	•					•				•		1645	148	44	8
1800	H088000713	PQ-1803.CD.M40.L/5	PQ-1803/5	2300				•		•				•		2115	148	44	11
	H088000712	PQ-1803.CD.M40.L/4	PQ-1803/4	1750			•			•				•		2115	148	44	11

Press range

Habasit presses are specifically designed to manage fabric belts, ensuring outstanding joining quality, reliability and flexibility.

Four different press series are available to meet different needs in terms of products to be processed, both on-site and on-premises.

Each series includes several press dimensions, available in mobile or stationary kits bundling the press body, the control unit and required accessories.

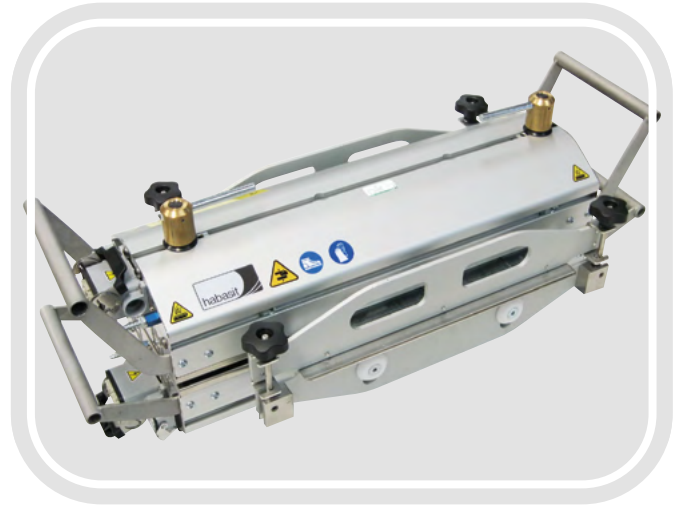

Choose your range														
Widths [mm]	300	600	800	1000	1200	1300	1600	2000	2200	2400	3200	3600	4200	
PM-09A Multipurpose	•	•		•		•	•	•						✿
PM-09W Multipurpose	•	•	•	•	•		•	•						💧
PM-HD High duty belts					•				•					💧
PM-04 Extra large										•	•	•	•	💧

Press range

PM-09A

The PM-09A is a lightweight and air-cooled hot-pressing series designed for on-site joining of conveyor belts up to 10 mm thick.

Thanks to a 160 mm wide heat equalization plate the press can also be used for 10/120 Flexproof geometry and step-flex (finger over finger) joining.

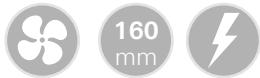

PM-09W

The PM-09W is a lightweight hot-pressing series designed for joining conveyor belts up to 10 mm thick. Thanks to a 160 mm wide heat equalization plate the press can also be used for 10/120 Flexproof geometry and step-flex (finger over finger) joining.

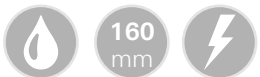

PM-HD

The PM-HD is a heavy duty hot-pressing series designed for joining heavy duty belts up to 12 mm thick. Thanks to a 200 mm wide equalization plate the press can also be used for step-joining of belts for marble and stone industries.

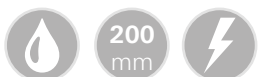

PM-04

The PM-04 is a range of hot-pressing devices, designed for wide belts up to 4200 mm wide and 10 mm thick. Thanks to a 160 mm wide heat equalization plate the press can be used also for 10/120 Flexproof geometry and step-flex (finger over finger) joining.

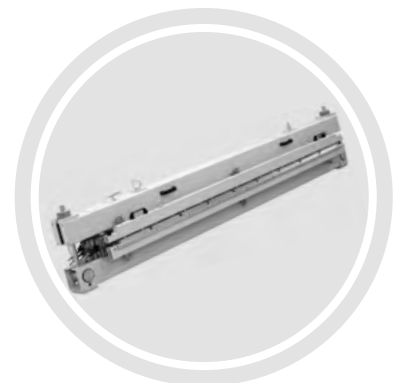
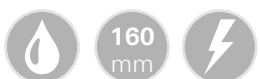



Control units

PMR control units are available in three different models to meet the requirement of different users and applications.

All the models provide an easy to use interface and, in combination with specific accessories, are able to manage the process parameters (such as temperature, pressure and time), ensuring a smooth joining process.

	PMR-08	PMR-07	PMR-103
			
			
Model	Pro	Lite	Portable
Temperature regulation	Yes Both plates Individual control	Yes Both plates Individual control	Yes Both plates Individual control
Time control	Yes	Yes	Yes
Joining parameters DB	Yes	No	No
Pressure control (Mobile)	By external compressor	By external compressor	No
Cooling control (Mobile)	Auto	Auto	Yes
Pressure control (Stationary)	Auto (PMC-06) or Manual (PCM-07)	Manual (PMC-07)	No
Cooling control (Stationary)	Auto (PMC-06) or auto (PCM-07)	Auto (PMC-07)	No

Cooling units and accessories

	PMC-06	PMC-07	PFC-07
			
Description	Cooling kit	Cooling kit	Cooling kit
Version	Stationary	Stationary	Stationary
Water cooling	Auto	Auto	Auto
Compressed air pad inflation	Auto	Manual	No

	PMC-04M	PMR-08-CB	MC-05/8
			
Description	Cooling kit	Connection box	Mini air compressor
Version	Mobile	Mobile	Mobile
Water cooling	Auto	No	No

Presses kits - Details

Details			Power supply				Dimensions *				Press details					
Max belt width	Ordering code	Article name	Power [W]	1 x 120 V	1 x 230 V	3 x 230 V	3 x 400 V	Length [mm]	Width [mm]	Height [mm]	Weight [kg]	Kit version	Control unit	Cooling unit		Press accessories
														Cooling kit	Connection box	
PM-09A air-cooled, multipurpose																
300	H088000345	PM-309/160A-M-CXM/4	1400			•		790	315	300	30	Mobile	PMR-07/4			MC-05/8
	H088000346	PM-309/160A-M-CXM/5	1400				•	790	315	300	30	Mobile	PMR-07/5			MC-05/8
	H088000347	PM-309/160A-M-CXM/8	1400		•			790	315	300	30	Mobile	PMR-07/8			MC-05/8
600	H088000350	PM-609/160A-M-CXM/8	2600		•			1080	315	300	44	Mobile	PMR-07/8			MC-05/8
	H088000348	PM-609/160A-M-CXM/4	2600			•		1080	315	300	44	Mobile	PMR-07/4			MC-05/8
	H088000349	PM-609/160A-M-CXM/5	2600				•	1080	315	300	44	Mobile	PMR-07/5			MC-05/8
1000	H088000352	PM-1009/160A-M-CXM/5	4000				•	1490	315	300	60	Mobile	PMR-07/5			MC-05/8
	H088000351	PM-1009/160A-M-CXM/4	4000				•	1490	315	300	60	Mobile	PMR-07/4			MC-05/8
1350	H088000311	PM-1359/160A-M-CXM/5	5600				•	1850	300	311	90	Mobile	PMR-07/5			MC-05/8
	H088000310	PM-1359/160A-M-CXM/4	5600				•	1850	300	311	90	Mobile	PMR-07/4			MC-05/8
1600	H088000247	PM-1609/160A-M-CXM/4	6400				•	2066	300	311	100	Mobile	PMR-07/4			MC-05/8
	H088000248	PM-1609/160A-M-CXM/5	6400				•	2066	300	311	100	Mobile	PMR-07/5			MC-05/8
2000	H088000398	PM-2009/160A-M-CXM/4	7200				•	2490	300	400	162	Mobile	PMR-07/4			MC-05/8
	H088000399	PM-2009/160A-M-CXM/5	7200				•	2490	300	400	162	Mobile	PMR-07/5			MC-05/8
PM-09W water-cooled, multipurpose																
300	H088000260	PM-309/160W-S-AAX/5	1120				•	675	380	300	31	Stationary	PMR-08/5	PMC-06		
	H088000264	PM-309/160W-M-APM/8	1120		•			675	380	300	31	Mobile	PMR-08/8	PMC-04M/8	PMR-08-CB	MC-05/8
	H088000263	PM-309/160W-M-APM/5	1120				•	675	380	300	31	Mobile	PMR-08/5	PMC-04M/8	PMR-08-CB	MC-05/8
	H088000261	PM-309/160W-S-AAX/8	1120		•			675	380	300	31	Stationary	PMR-08/8	PMC-06		
	H088000259	PM-309/160W-S-AAX/4	1120			•		675	380	300	31	Stationary	PMR-08/4	PMC-06		
	H088000258	PM-309/160W-M-CPM/8	1120		•			675	380	300	31	Mobile	PMR-07/8	PMC-04M/8		MC-05/8
	H088000257	PM-309/160W-M-CPM/6	1120	•				675	380	300	31	Mobile	PMR-07/6	PMC-04M/6		
	H088000256	PM-309/160W-M-CPM/5	1120				•	675	380	300	31	Mobile	PMR-07/5	PMC-04M/8		MC-05/8
	H088000251	PM-309/160W-S-CCX/4	1120			•		675	380	300	31	Stationary	PMR-07/4	PMC-07		
	H088000254	PM-309/160W-S-CCX/8	1120		•			675	380	300	31	Stationary	PMR-07/8	PMC-07		
	H088000253	PM-309/160W-S-CCX/6	1120	•				675	380	300	31	Stationary	PMR-07/6	PMC-07		
	H088000252	PM-309/160W-S-CCX/5	1120				•	675	380	300	31	Stationary	PMR-07/5	PMC-07		
	H088000255	PM-309/160W-M-CPM/4	1120				•	675	380	300	31	Mobile	PMR-07/4	PMC-04M/8		MC-05/8
	H088000262	PM-309/160W-M-APM/4	1120				•	675	380	300	31	Mobile	PMR-08/4	PMC-04M/8	PMR-08-CB	MC-05/8

* Weights and dimensions refer to the press main body excluding control unit, cooling unit and accessories.

Additional power supply configuration such as 3ph 415V, 440V, 460V and 480V are available upon request.

Presses kits - Details

Details			Power supply				Dimensions *				Press details					
Max belt width	Ordering code	Article name	Power [W]	Voltage				Length [mm]	Width [mm]	Height [mm]	Weight [kg]	Kit version	Control unit	Cooling unit		Press accessories
				1 x 120 V	1 x 230 V	3 x 230 V	3 x 400 V							Cooling kit	Connection box	
PM-09W water-cooled, multipurpose																
600	H088000274	PM-609/160W-S-AAX/8	2080	•			925	380	300	46	Stationary	PMR-08/8	PMC-06			
	H088000273	PM-609/160W-S-AAX/5	2080		•		925	380	300	46	Stationary	PMR-08/5	PMC-06			
	H088000272	PM-609/160W-S-AAX/4	2080		•		925	380	300	46	Stationary	PMR-08/4	PMC-06			
	H088000271	PM-609/160W-M-CPM/8	2080	•			925	380	300	46	Mobile	PMR-07/8	PMC-04M/8		MC-05/8	
	H088000270	PM-609/160W-M-CPM/5	2080		•		925	380	300	46	Mobile	PMR-07/5	PMC-04M/8		MC-05/8	
	H088000269	PM-609/160W-M-CPM/4	2080		•		925	380	300	46	Mobile	PMR-07/4	PMC-04M/8		MC-05/8	
	H088000268	PM-609/160W-S-CCX/8	2080	•			925	380	300	46	Stationary	PMR-07/8	PMC-07			
	H088000266	PM-609/160W-S-CCX/4	2080		•		925	380	300	46	Stationary	PMR-07/4	PMC-07			
	H088000276	PM-609/160W-M-APM/5	2080			•	925	380	300	46	Mobile	PMR-08/5	PMC-04M/8	PMR-08-CB	MC-05/8	
	H088000277	PM-609/160W-M-APM/8	2080		•		925	380	300	46	Mobile	PMR-08/8	PMC-04M/8	PMR-08-CB	MC-05/8	
	H088000267	PM-609/160W-S-CCX/5	2080			•	925	380	300	46	Stationary	PMR-07/5	PMC-07			
	H088000275	PM-609/160W-M-APM/4	2080			•	925	380	300	46	Mobile	PMR-08/4	PMC-04M/8	PMR-08-CB	MC-05/8	
800	H088000289	PM-809/160W-M-APM/5	2880			•	1120	380	300	55	Mobile	PMR-08/5	PMC-04M/8	PMR-08-CB	MC-05/8	
	H088000290	PM-809/160W-M-APM/8	2880	•			1120	380	300	55	Mobile	PMR-08/8	PMC-04M/8	PMR-08-CB	MC-05/8	
	H088000280	PM-809/160W-S-CCX/5	2880			•	1120	380	300	55	Stationary	PMR-07/5	PMC-07			
	H088000281	PM-809/160W-S-CCX/8	2880	•			1120	380	300	55	Stationary	PMR-07/8	PMC-07			
	H088000282	PM-809/160W-M-CPM/4	2880		•		1120	380	300	55	Mobile	PMR-07/4	PMC-04M/8		MC-05/8	
	H088000283	PM-809/160W-M-CPM/5	2880			•	1120	380	300	55	Mobile	PMR-07/5	PMC-04M/8		MC-05/8	
	H088000284	PM-809/160W-M-CPM/8	2880	•			1120	380	300	55	Mobile	PMR-07/8	PMC-04M/8		MC-05/8	
	H088000285	PM-809/160W-S-AAX/4	2880			•	1120	380	300	55	Stationary	PMR-08/4	PMC-06			
	H088000286	PM-809/160W-S-AAX/5	2880			•	1120	380	300	55	Stationary	PMR-08/5	PMC-06			
	H088000287	PM-809/160W-S-AAX/8	2880	•			1120	380	300	55	Stationary	PMR-08/8	PMC-06			
	H088000288	PM-809/160W-M-APM/4	2880			•	1120	380	300	55	Mobile	PMR-08/4	PMC-04M/8	PMR-08-CB	MC-05/8	
	H088000279	PM-809/160W-S-CCX/4	2880			•	1120	380	300	55	Stationary	PMR-07/4	PMC-07			

* Weights and dimensions refer to the press main body excluding control unit, cooling unit and accessories.

Additional power supply configuration such as 3ph 415V, 440V, 460V and 480V are available upon request.

Presses kits - Details

Details			Power supply						Dimensions *				Press details					
Max belt width	Ordering code	Article name	Power [W]	1 x 120 V	1 x 230 V	3 x 230 V	3 x 400 V	3 x 415 V	3 x 480 V	Length [mm]	Width [mm]	Height [mm]	Weight [kg]	Kit version	Control unit	Cooling unit		Press accessories
																Cooling kit	Connection box	
PM-09W water-cooled, multipurpose																		
1000	H088000083	PM-1009/160W-M-APM/4	3360			•				1350	380	300	69	Mobile	PMR-08/4	PMC-04M/8	PMR-08-CB	MC-05/8
	H088000173	PM-1009/160W-M-CPM/5	3360				•			1350	380	300	69	Mobile	PMR-07/5	PMC-04M/8		MC-05/8
	H088000180	PM-1009/160W-S-CCX/5	3360				•			1350	380	300	69	Stationary	PMR-07/5	PMC-07		
	H088000137	PM-1009/160W-S-AAX/4	3360			•				1350	380	300	69	Stationary	PMR-08/4	PMC-06		
	H088000112	PM-1009/160W-S-CCX/8	3360	•						1350	380	300	69	Stationary	PMR-07/8	PMC-07		
	H088000111	PM-1009/160W-S-AAX/5	3360			•				1350	380	300	69	Stationary	PMR-08/5	PMC-06		
	H088000110	PM-1009/160W-M-CPM/8	3360	•						1350	380	300	69	Mobile	PMR-07/8	PMC-04M/8		MC-05/8
	H088000182	PM-1009/160W-S-AAX/8	3360	•						1350	380	300	69	Stationary	PMR-08/8	PMC-06		
	H088000321	PM-1009/160W-M-CPM/4	3360			•				1350	380	300	69	Mobile	PMR-07/4	PMC-04M/8		MC-05/8
	H088000166	PM-1009/160W-M-APM/8	3360	•						1350	380	300	69	Mobile	PMR-08/8	PMC-04M/8	PMR-08-CB	MC-05/8
	H088000320	PM-1009/160W-S-CCX/4	3360			•				1350	380	300	69	Stationary	PMR-07/4	PMC-07		
H088000109	PM-1009/160W-M-APM/5	3360			•				1350	380	300	69	Mobile	PMR-08/5	PMC-04M/8	PMR-08-CB	MC-05/8	
1200	H088000187	PM-1209/160W-M-APM/4	4160			•				1630	400	300	92	Mobile	PMR-08/4	PMC-04M/8	PMR-08-CB	MC-05/8
	H088000322	PM-1209/160W-M-CPM/4	4160			•				1630	400	300	92	Mobile	PMR-07/4	PMC-04M/8		MC-05/8
	H088000233	PM-1209/160W-S-CCX/5	4160			•				1630	400	300	92	Stationary	PMR-07/5	PMC-07		
	H088000147	PM-1209/160W-M-APM/5	4160			•				1630	400	300	92	Mobile	PMR-08/5	PMC-04M/8	PMR-08-CB	MC-05/8
	H088000140	PM-1209/160W-M-CPM/5	4160			•				1630	400	300	92	Mobile	PMR-07/5	PMC-04M/8		MC-05/8
	H088000323	PM-1209/160W-S-CCX/4	4160			•				1630	400	300	92	Stationary	PMR-07/4	PMC-07		
	H088000312	PM-1209/160W-S-AAX/5	4160			•				1630	400	300	92	Stationary	PMR-08/5	PMC-06		
	H088000324	PM-1209/160W-S-AAX/4	4160			•				1630	400	300	92	Stationary	PMR-08/4	PMC-06		
H088000139	PM-1209/160W-R-CXX/5	4160			•				1630	400	300	92	Reduced	PMR-07/5				
1600	H088000360	PM-1609/160W-S-AAX/5	5200			•				1920	400	300	150	Stationary	PMR-08/5	PMC-06		
	H088000361	PM-1609/160W-M-APM/4	5200			•				1920	380	400	150	Mobile	PMR-08/4	PMC-04M/8	PMR-08-CB	MC-05/8
	H088000355	PM-1609/160W-S-CCX/4	5200			•				1920	380	400	150	Stationary	PMR-07/4	PMC-07		
	H088000356	PM-1609/160W-S-CCX/5	5200			•				1920	380	400	150	Stationary	PMR-07/5	PMC-07		
	H088000357	PM-1609/160W-M-CPM/4	5200			•				1920	380	400	150	Mobile	PMR-07/4	PMC-04M/8		MC-05/8
	H088000358	PM-1609/160W-M-CPM/5	5200			•				1920	380	400	150	Mobile	PMR-07/5	PM-04/8		MC-05/8
	H088000362	PM-1609/160W-M-APM/5	5200			•				1920	380	400	150	Mobile	PMR-08/5	PMC-04M/8	PMR-08-CB	MC-05/8
	H088000359	PM-1609/160W-S-AAX/4	5200			•				1920	380	400	150	Stationary	PMR-08/4	PMC-06		
	H088000620	PM-1609/160W-M-CPM/9	5200				•			1920	380	400	150	Mobile	PMR-07/9	PMC-04M/8		

* Weights and dimensions refer to the press main body excluding control unit, cooling unit and accessories.

Presses kits - Details

Details			Power supply					Dimensions *				Press details						
Max belt width	Ordering code	Article name	Power [W]	1 x 120 V	1 x 230 V	3 x 230 V	3 x 400 V	3 x 415 V	3 x 480 V	Length [mm]	Width [mm]	Height [mm]	Weight [kg]	Kit version	Control unit	Cooling unit		Press accessories
																Cooling kit	Connection box	
PM-09W water-cooled, multipurpose																		
2000	H088000371	PM-2009/160W-M-APM/5	6400			•				2320	380	400	174	Mobile	PMR-08/5	PMC-04M/8	PMR-08-CB	MC-05/8
	H088000365	PM-2009/160W-S-CCX/5	6400			•				2320	380	400	174	Stationary	PMR-07/5	PMC-07		
	H088000366	PM-2009/160W-M-CPM/4	6400			•				2320	380	400	174	Mobile	PMR-07/4	PMC-04M/8		MC-05/8
	H088000367	PM-2009/160W-M-CPM/5	6400			•				2320	380	400	174	Mobile	PMR-07/5	PMC-04M/8		MC-05/8
	H088000368	PM-2009/160W-S-AAX/4	6400			•				2320	380	400	174	Stationary	PMR-08/4	PMC-06		
	H088000369	PM-2009/160W-S-AAX/5	6400			•				2320	380	400	174	Stationary	PMR-08/5	PMC-06		
	H088000370	PM-2009/160W-M-APM/4	6400			•				2320	380	400	174	Mobile	PMR-08/4	PMC-04M/8	PMR-08-CB	MC-05/8
	H088000364	PM-2009/160W-S-CCX/4	6400			•				2320	380	400	174	Stationary	PMR-07/4	PMC-07		
PM-04 wide belts, multipurpose																		
2400	H080691141	PM-2404/160W-S-AAX/4	10800			•				2950	380	565	450	Stationary	PMR-08/4	PMC-06		
	H080691142	PM-2404/160W-S-AAX/5	10800			•				2950	380	565	450	Stationary	PMR-08/5	PMC-06		
	H080691143	PM-2404/160W-M-APM/4	10800			•				2950	380	565	450	Mobile	PMR-08/4	PMC-04M/8	PMR-08-CB	MC-05/8
	H080691144	PM-2404/160W-M-APM/5	10800			•				2950	380	565	450	Mobile	PMR-08/5	PMC-04M/8	PMR-08-CB	MC-05/8
	H088000245	PM-2404/160W-M-CPM/5	10800			•				2950	380	565	450	Mobile	PMR-07/5	PMC-04M/8		MC-05/8
	H080691180	PM-2404/160W-S-AAX 3x480	10800				•			2950	380	565	450	Stationary	PMR-08/3x480	PMC-06		
	H080691181	PM-2404/160W-M-APX 3x480	10800				•			2950	380	565	450	Mobile	MR-08/3x480	PMC-04M/8	PMR-08-CB	
3200	H080691154	PM-3204/160W-M-APM/5	8920			•				3655	380	665	620	Mobile	PMR-08/5	PMC-04M/8	PMR-08-CB	MC-05/8
	H080691151	PM-3204/160W-S-AAX/4	8920			•				3655	380	665	620	Stationary	PMR-08/4	PMC-06		
	H080691152	PM-3204/160W-S-AAX/5	8920			•				3655	380	665	620	Stationary	PMR-08/5	PMC-06		
	H080691153	PM-3204/160W-M-APM/4	8920			•				3655	380	665	620	Mobile	PMR-08/4	PMC-04M/8	PMR-08-CB	MC-05/8
	H080691182	PM-3204/160W-S-AAX 3x480	8920				•			3655	380	665	620	Stationary	PMR-08/3x480	PMC-06		
	H080691183	PM-3204/160W-M-APX 3x480	8920				•			3655	380	665	620	Mobile	MR-08/3x480	PMC-04M/8	PMR-08-CB	
3600	H080691157	PM-3604/160W-S-AAX/5	10180			•				4135	380	665	726	Stationary	PMR-08/5	PMC-06		
	H080691158	PM-3604/160W-M-APM/4	10180			•				4135	380	665	726	Mobile	PMR-08/4	PMC-04M/8	PMR-08-CB	MC-05/8
	H080691159	PM-3604/160W-M-APM/5	10180			•				4135	380	665	726	Mobile	PMR-08/5	PMC-04M/8	PMR-08-CB	MC-05/8
	H080691156	PM-3604/160W-S-AAX/4	10180			•				4135	380	665	726	Stationary	PMR-08/4	PMC-06		
	H080691184	PM-3604/160W-S-AAX 3x480	10180				•			4135	380	665	726	Stationary	MR-08/3x480	PMC-06		
	H080691185	PM-3604/160W-M-APX 3x480	10180				•			4135	380	665	726	Mobile	MR-08/3x480	PMC-06	PMR-08-CB	
4200	H080691161	PM-4204/160W-S-AAX/4	11600			•				4660	380	665	860	Stationary	PMR-08/4	PMC-06		
	H080691162	PM-4204/160W-S-AAX/5	11600			•				4660	380	665	860	Stationary	PMR-06/5	PMC-06		
	H080691163	PM-4204/160W-M-APM/4	11600			•				4660	380	665	860	Mobile	PMR-08/4	PMC-04M/8	PMR-08-CB	MC-05/8
	H080691164	PM-4204/160W-M-APM/5	11600			•				4660	380	665	860	Mobile	PMR-08/5	PMC-04M/8	PMR-08-CB	MC-05/8
	H080691186	PM-4204/160W-S-AAX 3x480	11600				•			4660	380	665	860	Stationary	MR-08/3x480	PMC-06		
	H080691187	PM-4204/160W-M-APX 3x480	11600				•			4660	380	665	860	Mobile	MR-08/3x480	PMC-04M/8	PMR-08-CB	
PM-HD high duty																		
1200	H088000503	PM-12HD/200W-M-CXX/5	5720			•				1550	420	360	173	Mobile	PMR-07/5			
2200	H088000504	PM-22HD/200W-M-CXX/5	10080			•				2750	450	560	410	Mobile	PMR-07/5			

* Weights and dimensions refer to the press main body excluding control unit, cooling unit and accessories.

Presses for timing belts

PF-150C

Water-cooled hot-pressing device for Flexproof joining of Habasit timing belts up to a width of 150 mm / 6 in. and a thickness of 11 mm / 0.43 in. Pressing temperature is controlled individually on top and bottom heating plates with an electronic temperature regulator; maximum temperature is 200 °C / 392 °F. A positioning system ensures precise and straight joints.

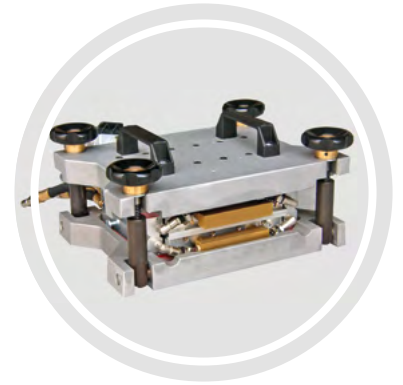

PF-201TB

Water-cooled hot-pressing device for Flexproof joining of Habasit timing belts up to a width of 200 mm / 8 in. A PMR control unit manages the pressing temperature (controlled individually on top and bottom heating plates) and the cooling cycle through a connection with the PMC cooling device. It is designed to be installed on a press bench and it is the ideal solution for high-productive Habasit workshops.

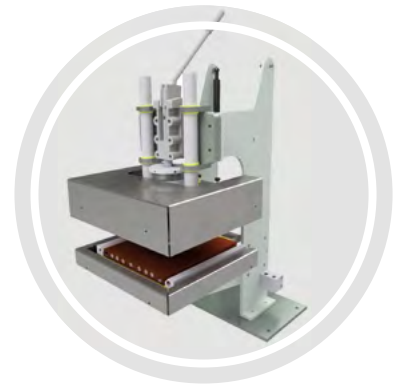

Details			Power supply						Dimensions *				Press details				
Max belt width	Ordering code	Article name	Power [W]	1 x 120 V	1 x 230 V	3 x 230 V	3 x 400 V	3 x 415 V	3 x 480 V	Length [mm]	Width [mm]	Height [mm]	Weight [kg]	Kit version	Control unit	Cooling kit	Press accessories
Presses for timing belts																	
150	H080693020	PF-150C-S-CFT/6	3600	•						510	350	180	33	Stationary	PMR-07/6	PFC-07	Torque wrench
	H080693030	PF-150C-S-CFT/8	3600		•					510	350	180	33	Stationary	PMR-07/8	PFC-07	Torque wrench
	H088000223	PF-150C-S-CFT/9	3600					•		510	350	180	33	Stationary	PMR-07/9	PFC-07	Torque wrench
	H088000470	PF-150C-W-AFP/8	3600		•					510	350	180	114	Workshop	PMR-08/8	PFC-07	PF-150CW
	H088000116	PF-150C-W-CFP/6	3600	•						510	350	180	114	Workshop	PMR-07/6	PFC-07	PF-150CW
200	H088000115	PF-150C-W-CFP/8	3600		•					510	350	180	114	Workshop	PMR-07/8	PFC-07	PF-150CW
	H088000659	PF-201TB-W-AAP/5	12000				•			490	380	776	105	Workshop	PMR-08/5	PMC-06	
	H088000747	PF-201TB-W-CFP/5	12000				•			490	380	776	105	Workshop	PMR-07/5	PFC-07	

* Weights and dimensions refer to the press main body excluding control unit, cooling unit and accessories.

Joining plates for timing belts

When HabaSYNC® timing belts need to be joined, Habasit joining plates provide outstanding results and smooth pulley engagement. Thanks to a special micro-coating, Habasit joining plates have excellent anti-sticking properties. A huge variety of pitch-width alternatives is available to cover every situation, including both metric and imperial standard pitches.

Metric pitch						
Width [mm]	Ordering code	Product name	Ordering code	Product name	Ordering code	Product name
	T5		T10		T20	
10	H088000105	CJ-T5-10-03				
16	H088000002	CJ-T5-16-03	H088000010	CJ-T10-16-03	H088000018	CJ-T20-16-03
25	H088000003	CJ-T5-25-03	H088000011	CJ-T10-25-03	H088000019	CJ-T20-25-03
32	H088000004	CJ-T5-32-03	H088000012	CJ-T10-32-03	H088000020	CJ-T20-32-03
50	H088000005	CJ-T5-50-03	H088000013	CJ-T10-50-03	H088000021	CJ-T20-50-03
75	H088000006	CJ-T5-75-03	H088000014	CJ-T10-75-03	H088000022	CJ-T20-75-03
100	H088000007	CJ-T5-100-03	H088000015	CJ-T10-100-03	H088000023	CJ-T20-100-03
125	H088000008	CJ-T5-125-03	H088000016	CJ-T10-125-03	H088000024	CJ-T20-125-03
150	H088000009	CJ-T5-150-03	H088000017	CJ-T10-150-03	H088000025	CJ-T20-150-03

Metric pitch						
Width [mm]	Ordering code	Product name	Ordering code	Product name	Ordering code	Product name
	AT5		AT10		AT20	
16	H088000026	CJ-AT5-16-03	H088000034	CJ-AT10-16-03	H088000042	CJ-AT20-16-03
25	H088000027	CJ-AT5-25-03	H088000035	CJ-AT10-25-03	H088000043	CJ-AT20-25-03
32	H088000028	CJ-AT5-32-03	H088000036	CJ-AT10-32-03	H088000044	CJ-AT20-32-03
50	H088000029	CJ-AT5-50-03	H088000037	CJ-AT10-50-03	H088000045	CJ-AT20-50-03
75	H088000030	CJ-AT5-75-03	H088000038	CJ-AT10-75-03	H088000046	CJ-AT20-75-03
100	H088000031	CJ-AT5-100-03	H088000039	CJ-AT10-100-03	H088000047	CJ-AT20-100-03
125	H088000032	CJ-AT5-125-03	H088000040	CJ-AT10-125-03	H088000048	CJ-AT20-125-03
150	H088000033	CJ-AT5-150-03	H088000041	CJ-AT10-150-03	H088000049	CJ-AT20-150-03

Metric pitch								
Width [mm]	Ordering code	Product name	Ordering code	Product name	Ordering code	Product name	Ordering code	Product name
	5M		8M		14M		RPP8	
10	H088000124	CJ-HTD5-10-03	H088000084	CJ-HTD8-10-03	H088000094	CJ-HTD14-10-03		
15	H088000125	CJ-HTD5-15-03	H088000085	CJ-HTD8-15-03	H088000095	CJ-HTD14-15-03		
20	H088000174	CJ-HTD5-20-03	H088000086	CJ-HTD8-20-03	H088000096	CJ-HTD14-20-03	H08D010067	CJ-RPP8-20-03
25	H088000126	CJ-HTD5-25-03	H088000087	CJ-HTD8-25-03	H088000097	CJ-HTD14-25-03		
30	H088000175	CJ-HTD5-30-03	H088000088	CJ-HTD8-30-03	H088000098	CJ-HTD14-30-03		
40	H088000176	CJ-HTD5-40-03	H088000089	CJ-HTD8-40-03	H088000099	CJ-HTD14-40-03		
50	H088000127	CJ-HTD5-50-03	H088000090	CJ-HTD8-50-03	H088000100	CJ-HTD14-50-03	H08D010065	CJ-RPP8-50-03
55					H088000122	CJ-HTD14-55-03		
85			H088000091	CJ-HTD8-85-03	H088000101	CJ-HTD14-85-03	H08D010063	CJ-RPP8-85-03
100	H088000178	CJ-HTD5-100-03	H088000092	CJ-HTD8-100-03	H088000102	CJ-HTD14-100-03	H08D010061	CJ-RPP8-100-03
115					H088000123	CJ-HTD14-115-03		
150	H088000179	CJ-HTD5-150-03	H088000093	CJ-HTD8-150-03	H088000103	CJ-HTD14-150-03	H08D010059	CJ-RPP8-150-03

Joining plates for timing belts

Imperial pitch								
Width [inch]	Ordering code	Product name	Ordering code	Product name	Ordering code	Product name	Ordering code	Product name
	XL		L		H		XH	
0.5	H088000107	CJ-XL-050-03	H088000108	CJ-L-050-03	H088000106	CJ-H-050-03		
0.75	H088000074	CJ-XL-075-03	H088000076	CJ-L-075-03	H088000078	CJ-H-075-03	H088000080	CJ-XH-075-03
1	H088000050	CJ-XL-100-03	H088000056	CJ-L-100-03	H088000062	CJ-H-100-03	H088000068	CJ-XH-100-03
1.5	H088000075	CJ-XL-150-03	H088000077	CJ-L-150-03	H088000079	CJ-H-150-03	H088000081	CJ-XH-150-03
2	H088000051	CJ-XL-200-03	H088000057	CJ-L-200-03	H088000063	CJ-H-200-03	H088000069	CJ-XH-200-03
3	H088000052	CJ-XL-300-03	H088000058	CJ-L-300-03	H088000064	CJ-H-300-03	H088000070	CJ-XH-300-03
4	H088000053	CJ-XL-400-03	H088000059	CJ-L-400-03	H088000065	CJ-H-400-03	H088000071	CJ-XH-400-03
5	H088000054	CJ-XL-500-03	H088000060	CJ-L-500-03	H088000066	CJ-H-500-03	H088000072	CJ-XH-500-03
6	H088000055	CJ-XL-600-03	H088000061	CJ-L-600-03	H088000067	CJ-H-600-03	H088000073	CJ-XH-600-03

Sketches

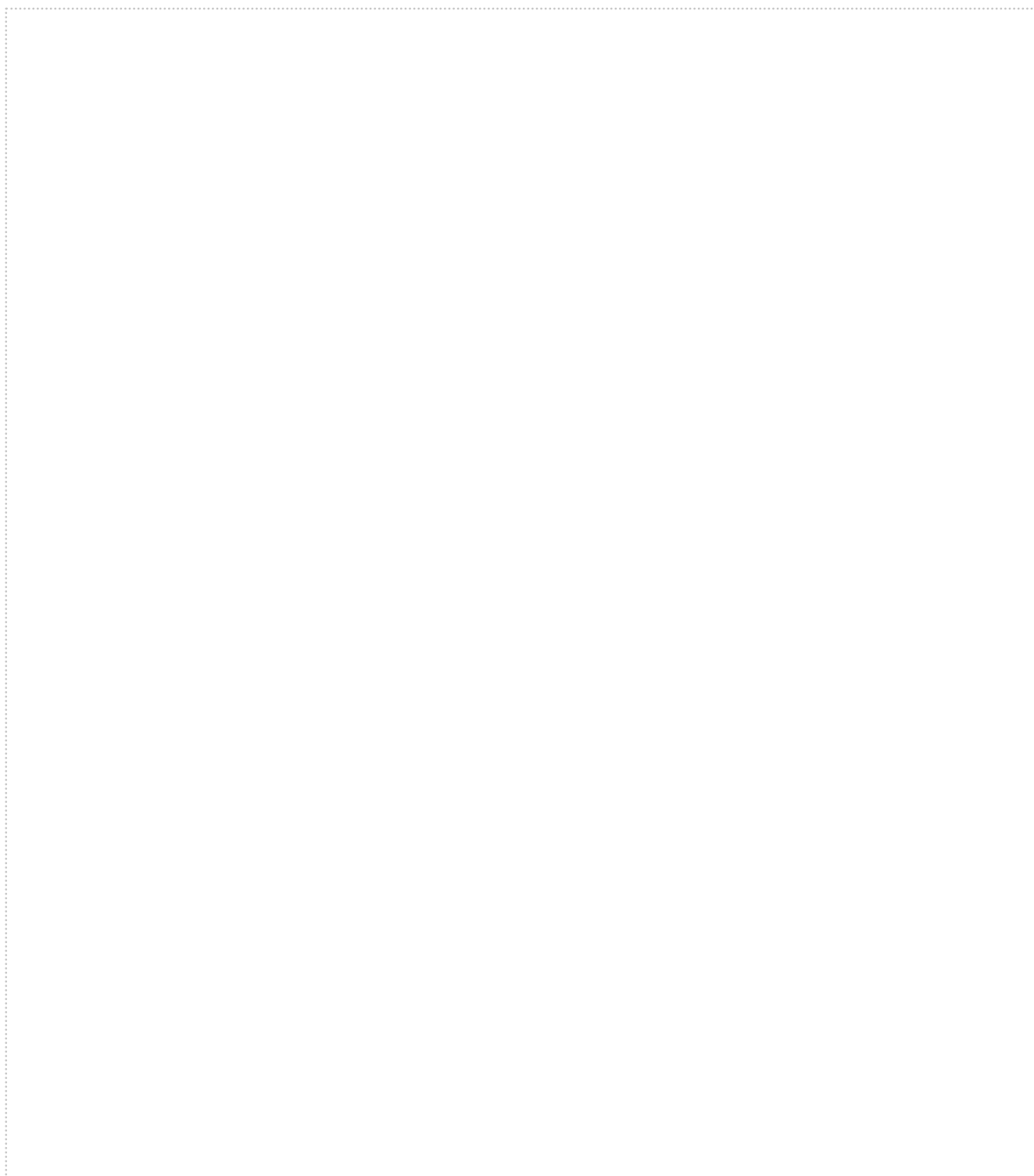

Notes



A series of horizontal dotted lines spanning the width of the page, providing a template for handwritten notes.

Notes



A series of horizontal dotted lines spanning the width of the page, providing a template for writing notes.

Our services



Our commitment to our customers' success is what drives our continuous innovation and product and service improvements.

We combine engineering expertise with dedication to reliability, to create lasting value for our customers.

Global leadership, local service

Habasit is your local partner with global reach. With 30 affiliated companies, each with its own inventory, fabrication, assembly, and service facilities, plus our worldwide network of partners, we react quickly and expertly to meet your most complex installation challenges.



Comprehensive technical support

from belt selection to design assistance
Extensive knowledge of our customers' processes lets us guide you from application analysis to selecting the optimal solution. We offer online calculation and belt selection tools, as well as on-site engineering assistance and equipment design, to make sure you get the best solution.



Process optimization and everyday efficiency

Innovation comes from understanding our customers' daily challenges. Habasit is more than a belting company. Our experts can provide belt condition monitoring, regular inspections, analysis, and surveys at your sites, to keep your lines running smoothly and fully optimize your equipment and production processes.



Sharing knowledge and making business easy

Habasit offers training programs and support tools to ensure optimal use of our products, with training on fabrication, installation, assembly, maintenance and belt repair either at a Habasit site or your own location. Orders, shipping and tracking can be managed via our Customer Care team, or directly online.

Committed to innovation beyond the obvious

Because our customers' challenges and needs are always changing, we are constantly investing in the research and development of new products and solutions not only for today, but also for tomorrow.

Habasit is a member of EHEDG

Our dedicated belting solutions aim to support the highest standards of hygienic equipment design.



Contact us

Habasit has subsidiaries, affiliated companies, representatives and service partners all around the world, dedicated to supporting you whenever and wherever you need us.



Australia

Habasisit Australia Pty Ltd.
Silverwater, Sydney
☎ +61 1300 945 455
🌐 habasisit.com.au

Austria

Habasisit GmbH, Wiener Neudorf
☎ +43 1 690 66
🌐 habasisit.at

Belgium & Luxembourg

Habasisit Belgium N.V., Zaventem
☎ +32 27 250 430
🌐 habasisit.be | habasisit.lu

Brazil

Habasisit do Brasil, Barueri - SP
☎ +55 11 4789 9022
🌐 habasisit.com.br

Canada

Habasisit Canada Ltd., Oakville
☎ +1 905 827 41 31
🌐 habasisit.ca

China

Habasisit East Asia Ltd.
Fotan, Shatin, N.T., Hong Kong
☎ +852 2145 0150
🌐 habasisit.com.hk

Habasisit (Shanghai) Co. Ltd.
Shanghai
☎ +8621 5488 1218
🌐 habasisit.com.cn

Denmark

Habasisit AB, Vejle, Denmark
☎ +45 23 26 56 57
🌐 habasisit.com

France

Habasisit France S.A.S., Mulhouse
☎ +33 3 89 33 89 03
🌐 habasisit.fr

Germany

Habasisit GmbH, Eppertshausen
☎ +49 6071 969 0
🌐 habasisit.de

India

Habasisit India Private Limited,
Coimbatore
☎ +91 422 666 78 00
🌐 habasisit.in

Italy

Habasisit Italiana SpA
☎ Customer Care: 0438 911333
☎ For int. calls: +39 0438 911444
🌐 habasisit.com

Japan

Habasisit Nippon Co., Ltd, Tokyo
☎ +81 120 07 6339
🌐 habasisit.co.jp

Korea (Republic of)

Habasisit Korea Ltd.,
Seongnam City
☎ +82 31 737 9370
🌐 www.habasisit.co.kr

Mexico

Habasisit México, Zapopan
☎ +52 33 3824 2358
🌐 habasisitmexico.com

Netherlands

Habasisit Netherlands BV, Nijkerk
☎ +31 332 472 030
🌐 habasisit.nl

New Zealand

Habasisit New Zealand Pty Ltd.
Auckland
☎ 0800 000 070
🌐 habasisit.co.nz

Norway

Habasisit Norge AS, Kleppestø,
☎ +47 23 96 0725
🌐 habasisit.com

Poland

Habasisit Polska Sp. z o.o.
Czeladź
☎ +48 32 639 02 40
🌐 habasisit.pl

Romania

Habasisit Belting SRL
Timisoara
☎ +40 256 704 500
🌐 habasisit.ro

Russia

OOO Habasisit Ltd.
Moscow Region
☎ +7 495 966 1566
🌐 habasisit.ru

Singapore

Habasisit Far East Pte Ltd.
Singapore
☎ +65 6862 5566
🌐 habasisit.com.sg

South Africa

Habasisit South Africa Pty Ltd.
Gauteng
☎ +27 10 001 6770
🌐 habasisit.co.za

Spain

Habasisit Hispánica S.A.
Barberá del Vallés
☎ +34 937 191 912
🌐 habasisit.es

Sweden

Habasisit AB, Hindås
☎ +46 301 226 00
🌐 habasisit.se

Switzerland

Habasisit GmbH, Reinach
☎ +41 61 577 51 00
🌐 habasisit.ch

Taiwan

Habasisit (Taiwan) Ltd.
New Taipei City
☎ +886 2 2267 0538
🌐 habasisit.com.tw

Turkey

Habasisit Kayis San.
Ve Tic. Ltd. Sti., Istanbul
☎ +90 444 70 43
🌐 habasisit.com.tr

Ukraine

Habasisit Ukraine LLC., Kyiv
☎ +38 044 290 88 99
🌐 habasisit.ua

United Kingdom & Ireland

Habasisit UK Ltd., Elland
☎ +44 333 207 6570
🌐 habasisit.co.uk

USA

Habasisit America
Suwanee, Georgia
☎ +1 800 458 6431
🌐 habasisitamerica.com

Habasit International AG

Römerstrasse 1

CH-4153 Reinach, Switzerland

 +41 61 715 15 15

 +41 61 715 15 55

 [habasit.com](https://www.habasit.com)

Registered trademarks

Copyright Habasit International AG

Subject to alterations

4005BRO.TOL-en0525ITA

Information provided herein does not constitute legal representations or warranties and may change without notice.

Please refer to the specifications/disclaimers provided in the respective product data sheets.